

OSCILLATING MOUNTING TYPE AR

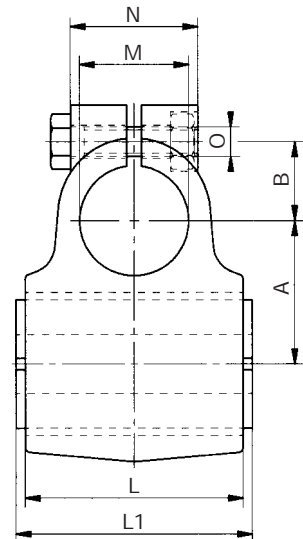
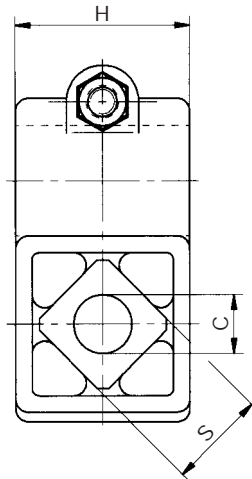

Art. No.	Type	G			n _{err}	Md _d	Dimensions in mm										Weight in kg
		K=2	K=3	K=4			A	B	C	H	L	L1	M	N	O	S	
07 291 003	AR 27	300	240	200	590	2.6	39 ^{+0.2}	21.5	16 ^{+0.5} _{-0.3}	48	60	65 ^{-0.3}	30	35	M8	27	0.45
07 291 004	AR 38	600	500	400	510	6.7	52 ^{+0.2}	26.5	20 ^{+0.5} _{-0.2}	64	80	90 ^{-0.3}	40	50	M8	38	0.95

G = max. load in G per rocker

K = oscillating machine factor

n_{err} = max. frequency in min⁻¹ with $\pm 5^\circ$

Md_d = dynamic spring value in Nm/° at $\pm 5^\circ$, in frequency range 300–600 min⁻¹

Material Structure

Housings in light metal die cast, inner square in light alloy profile.

Single Drive Head

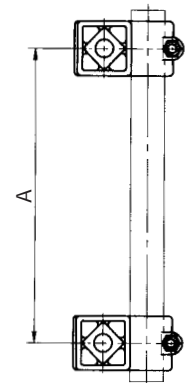
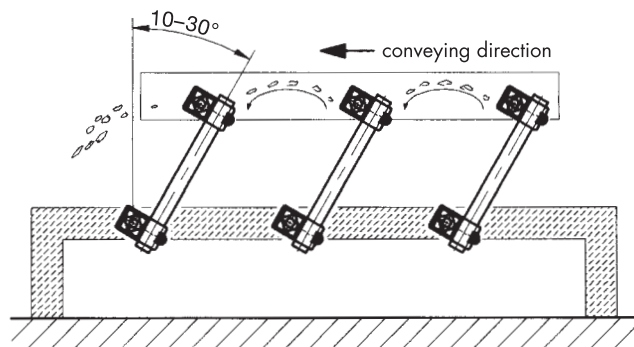

ROSTA oscillating mountings type AR in **single rocker configuration**: mounted on a round tube. It is best to adjust the desired center-distance between the axes on a surface plate and to subsequently tighten the clamp in order to frictionally connect the circular tube. The unit is fixed to the trough and the machine frame by means of frictional connection to the inner square section of the element by means of a bolt.

Dynamic Spring Value

The dynamic spring value c_d of an oscillation unit consisting of 2 elements, type AR, is calculated as following:

$$c_d = \frac{Md_d \cdot 360 \cdot 1000}{A^2 \cdot \pi} = [\text{N/mm}]$$

OSCILLATING MOUNTING TYPE AR

Double Drive Head

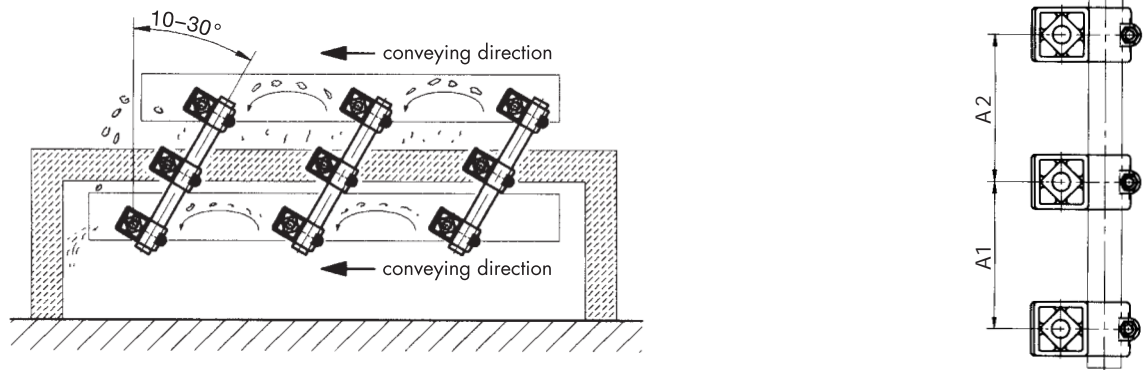

ROSTA oscillating mountings type AR in **double rocker configuration**: These elements are mounted in the same way as the single rocker arms. However, the material thickness of the round connection tube must be adapted according to the final center distances (see table on bottom left of this page). The double rocker arm allows easy installation in high-speed two-mass shaker conveyors with direct balancing. The counterweight can be used as additional conveyor trough. The material flows in the same direction, both on the trough and the counterweight.

Bidirectional Drive Head

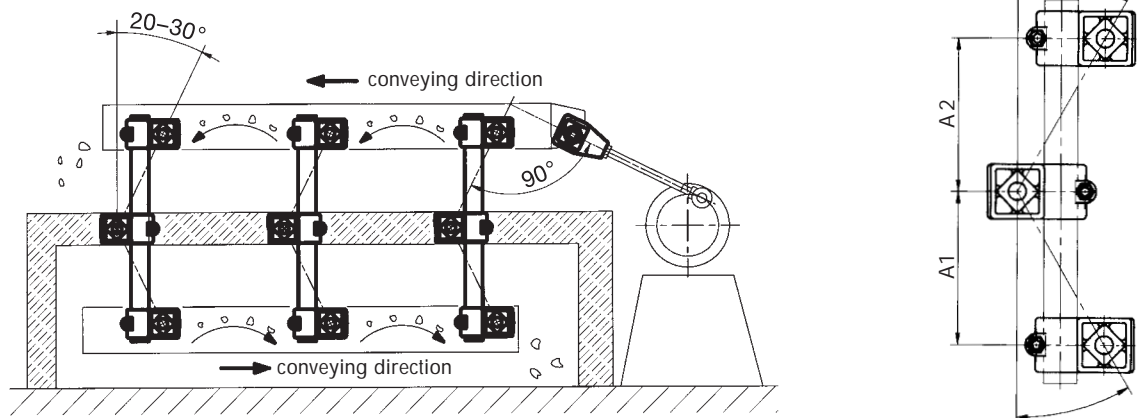

ROSTA oscillating mountings type AR in **boomerang configuration** for bidirectional conveying. The double rocker is mounted vertically, the middle element is rotated by 180°. The angles of the double rocker go in opposite direction, causing the material on the counterweight to move in opposite direction, too. The bidirectional conveying allows an easier processing of the bulk material, but still guarantees a perfect balancing of masses for high-speed oscillating conveyors.

Dynamic Spring Value

The dynamic spring value c_d of an oscillation unit consisting of 3 elements, type AR, is calculated as following:

$$c_d = \frac{3 \cdot 360 \cdot Md_d \cdot 1000}{4 \cdot \pi} \cdot \left(\frac{1}{A1^2} + \frac{1}{A2^2} \right) = [\text{N/mm}]$$

c_d = dynamic spring value in N/mm with torsion $\pm 5^\circ$,
frequency range 300–600 min⁻¹

Dimensions of the Connecting Tubes

(to be provided by the customer)

Type	Dimensions in mm		
	Tube Ø	min. thickness of tube	max. A1 or A2
AR 27	30	3*	160
	30	4	220
	30	5	300
AR 38	40	3*	200
	40	4	250
	40	5	300

* for single drive heads always use a thickness of 3 mm